

Name: Scott Hughes
 Date: _____
 Track: The Farm 2

Track Conditions

Size: Open Med. Tight
 Traction: High Med. Low
 Surface: Smooth Med. Bumpy

Front Suspension

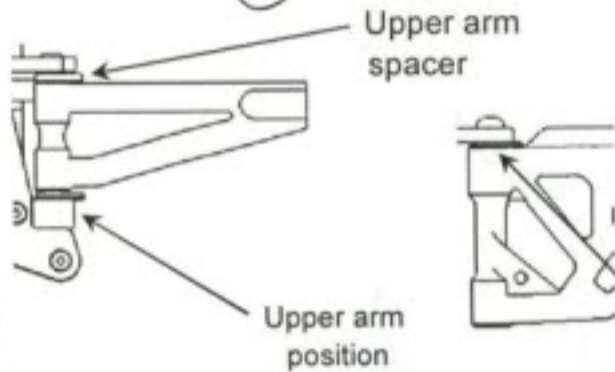
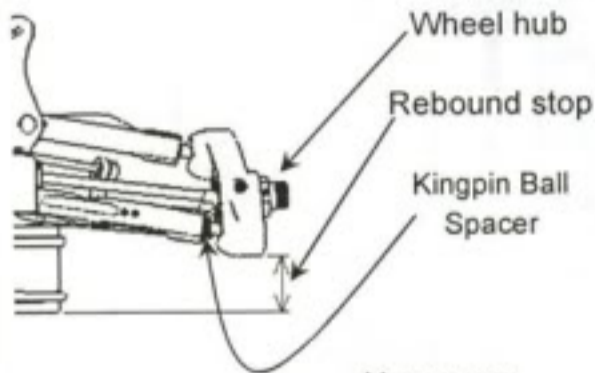

Kingpin ball spacer 1 mm
 Camber angle -1 °
 Upper arm spacer 4 mm
 Toe angle +1 °
 Rebound stop 21 mm
 Anti-roll bar φ 2.5 mm
 Wheel Hub 0 mm
 Lower arm mount (Kick up) 0 1



Lower arm plate (E0154A)

Upper arm position (E0148B, E0148C)

Lower arm spacer 2 mm

Front Shocks

Piston 1.2
 Oil # 400
 Spring med
 Spring adjustment 2.9 mm

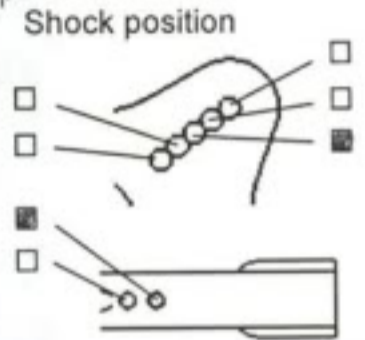
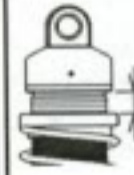

Steering Ackerman

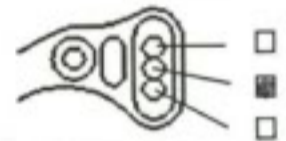

Rear Suspension

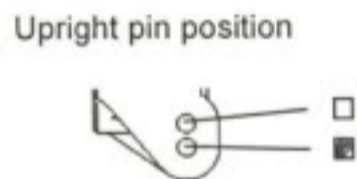
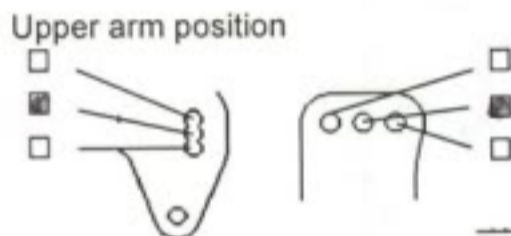
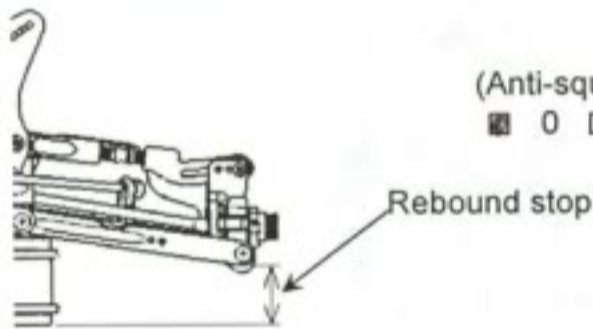

(Anti-squat) 0 1
 (Toe angle) 3 °

Rebound stop 19.6 mm
 Anti-roll bar φ 2.8 mm
 Anti-squat (E0111C, E0111D)

Upright E0152
 E0173 (Aluminium)

Wheelbase adjustment 2 mm

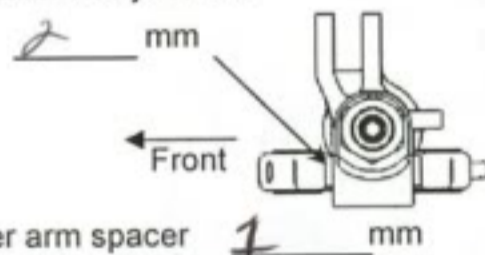

Rear Shocks

Piston 1.2
 Oil # 350
 Spring soft
 Spring adjustment 2.3 mm

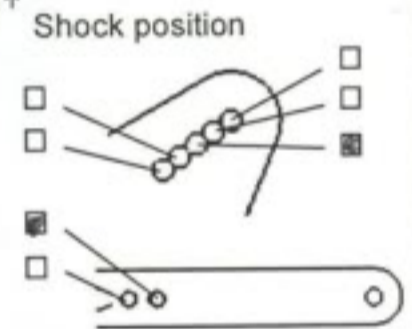

Wing Position



Engine Type 2.5 Speed
 Gasket _____ mm Reducer φ 5.5
 Plug P3 Fuel 30% Mugen
 Muffler 2060

Diff. Oil Front # 5 O-Ring 1 gasket pcs. Other _____
 Center # 7 0 pcs. Other _____
 Rear # 2 0 pcs. Other _____

Tire Front Type Revolver M3 Rear Type Revolver M3
 Foam Pro-Line Foam Pro-Line

Clutch Clutch shoes Aluminium _____
 Other _____
 Spring 1.0 mm
 Clutch bell / Spur gear 14 T146T

Result Race time / Lap _____
 Best lap (1Lap) _____

Comments: _____

