

Name: _____
Date: _____
Track: _____

Track Conditions

Size: Open Med. Tight
 Traction: High Med. Low
 Surface: Smooth Med. Bumpy

Front Suspension

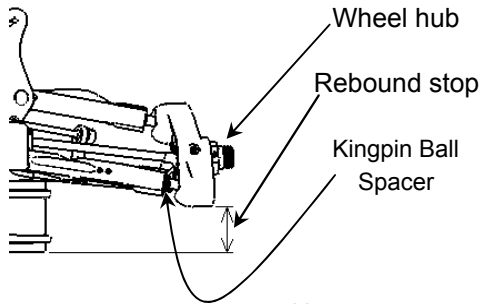

Kingpin ball spacer _____ mm
 Camber angle _____ °
 Upper arm spacer _____ mm
 Toe angle _____ °
 Rebound stop _____ mm
 Anti-roll bar φ _____ mm
 Wheel Hub _____ mm
 Lower arm mount (Kick up) _____ mm

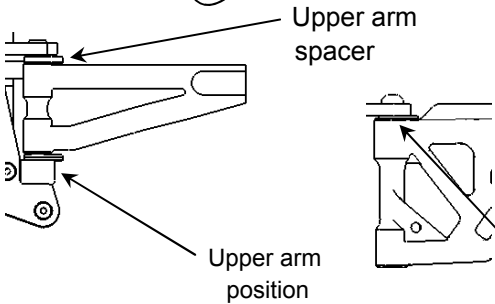

0
 1

Lower arm plate (E0154A)

Upper arm position(E0148B,E0148C)

Lower arm spacer _____ mm

Front Shocks

Piston _____
 Oil # _____
 Spring _____
 Spring adjustment _____ mm

Shock position

Steering Ackerman

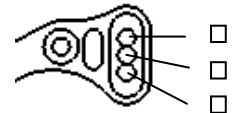

Rear Suspension

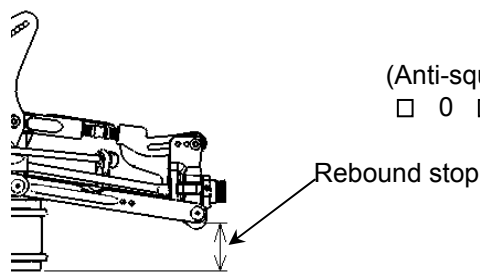

Camber angle _____ °
 Lower arm mount _____ mm
 (Anti-squat) 0 1
 (Toe angle) _____ °
 Rebound stop _____ mm
 Anti-roll bar φ _____ mm
 Anti-squat (E0111C,E0111D) _____ mm

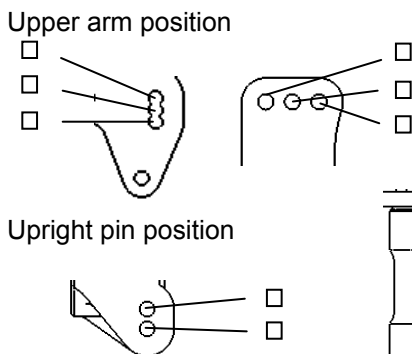

Upright E0152
 E0173(Aluminium)

Wheelbase adjustment _____ mm

Lower arm spacer _____ mm

Rear Shocks

Piston _____
 Oil # _____
 Spring _____
 Spring adjustment _____ mm

Shock position

Wing Position

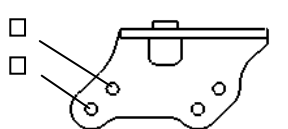

Engine Type _____
 Gasket _____ mm Reducer φ _____
 Plug _____ Fuel _____
 Muffler _____

Diff. Oil
 Front # _____ O-Ring _____ pcs. Other _____
 Center # _____ _____ pcs. Other _____
 Rear # _____ _____ pcs. Other _____

Tire

Front	Rear
Type _____	Type _____
Foam _____	Foam _____

Clutch Clutch shoes Aluminium _____
 Other _____
 Spring _____ mm
 Clutch bell / Spur gear **T / T**

Result
 Race time / Lap _____
 Best lap (1Lap) _____

Comments:

