

Name: _____
Date: _____
Track: _____

Track Conditions

Size:	<input type="checkbox"/> Open	<input type="checkbox"/> Med.	<input type="checkbox"/> Tight
Traction:	<input type="checkbox"/> High	<input type="checkbox"/> Med.	<input type="checkbox"/> Low
Surface:	<input type="checkbox"/> Smooth	<input type="checkbox"/> Med.	<input type="checkbox"/> Bumpy

Front Suspension

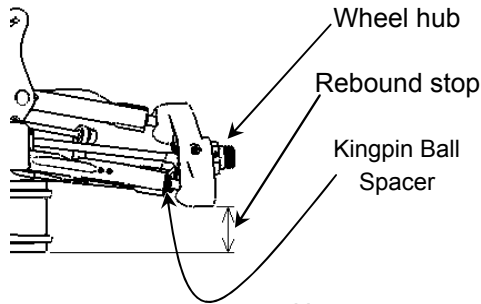

Kingpin ball spacer _____ mm
 Camber angle _____ °
 Upper arm spacer _____ mm
 Toe angle _____ °
 Rebound stop _____ mm
 Anti-roll bar φ _____ mm
 Wheel Hub _____ mm
 Lower arm mount (Kick up)



Lower arm plate (E0154A)

Upper arm position (E0148B, E0148C)

Lower arm spacer _____ mm

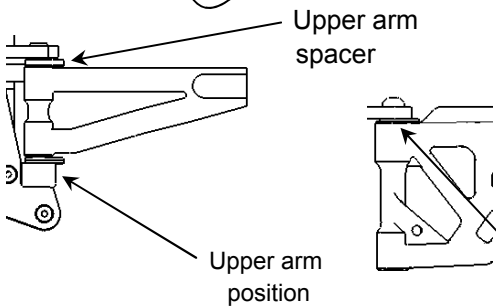

Front Shocks

Piston _____
 Oil # _____
 Spring _____
 Spring adjustment _____ mm
 Shock position

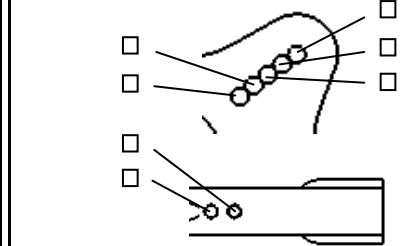

Steering Ackerman

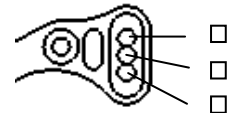

Rear Suspension

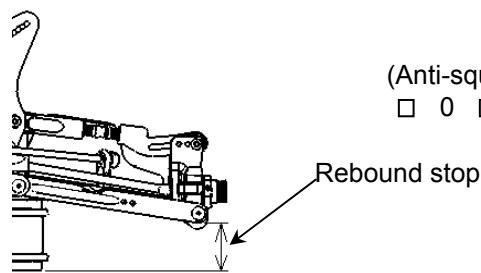

Camber angle _____ °
 Lower arm mount _____ °
 (Anti-squat) 0 1
 (Toe angle) _____ °
 Rebound stop _____ mm
 Anti-roll bar φ _____ mm
 Anti-squat (E0111C, E0111D)



Upright E0152
 E0173 (Aluminium)

Wheelbase adjustment

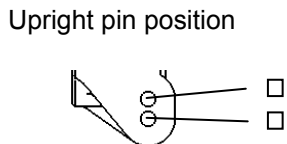
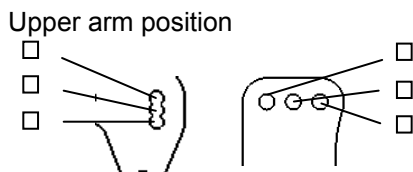
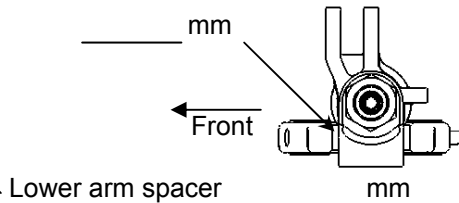

Rear Shocks

Piston _____
 Oil # _____
 Spring _____
 Spring adjustment _____ mm
 Shock position

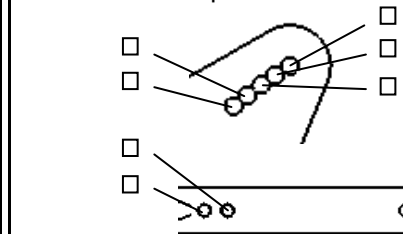

Wing Position

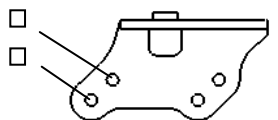

Engine	Type _____	Gasket _____ mm	Reducer φ _____
	Plug _____	Fuel _____	
	Muffler _____		

Diff. Oil	Front # _____	O-Ring _____ pcs.	<input type="checkbox"/> Other _____
	Center # _____	_____ pcs.	<input type="checkbox"/> Other _____
	Rear # _____	_____ pcs.	<input type="checkbox"/> Other _____

Tire	Front	Rear
	Type _____	Type _____
	Foam _____	Foam _____

Clutch	Clutch shoes <input type="checkbox"/> Aluminium _____
	<input type="checkbox"/> Other _____
	Spring _____ mm
	Clutch bell / Spur gear T / T

Result
 Race time / Lap _____
 Best lap (1Lap) _____

Comments:

